

Type 850/860/870 Series

Miniature Air and Water Pressure Regulators

Type 850 Miniature Air Pressure Regulator

Type 860 Miniature Water Pressure Regulator

Type 870 Miniature Potable Water Pressure Regulator

The ControlAir Type 850/860/870 Series are compact units that provide economical, high performance pressure regulation of compressed air (Type 850), water (Type 860) or drinkable water (Type 870). Designed specifically for the OEM market, these units are ideal for compressed air or water pressure control applications. The highly sensitive diaphragm-operated design delivers accurate downstream pressure by eliminating the problems caused by sticking in piston designs utilized by competitors. A molded rubber supply valve provides accurate regulation and helps prevent leakage.

The Type 850/860 is recommended for use in any industrial application that requires water or air pressure regulation and low cost. The Type 870 is designed for use in potable water systems. Materials in contact with water are approved by National Sanitation Foundation (NSF) or the Food and Drug Administration (FDA) for use in potable water systems. Elastomers in the Type 870 are food grade.



Type 850/860/870 Flow Characteristics

Features

- Easy and Accurate Adjustment
- Relieving and Non-relieving Models
- 1/8" and 1/4" NPT and BSP Porting
- Compact & Lightweight
- Low Cost

Type 850

1/4" NPT Port, 0-100 psig Range, 100 psig Supply;
Flows for Outputs of 20, 40, 60, & 80 psig

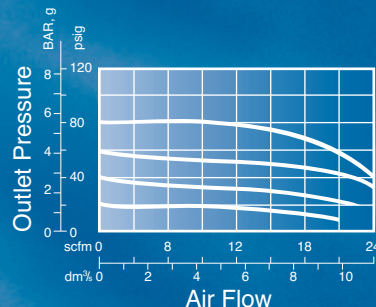

Type 860 / Type 870

1/4" NPT Port, 0-100 psig Range, 100 psig Supply;
Flows for Outputs of 20, 40, 60, & 80 psig

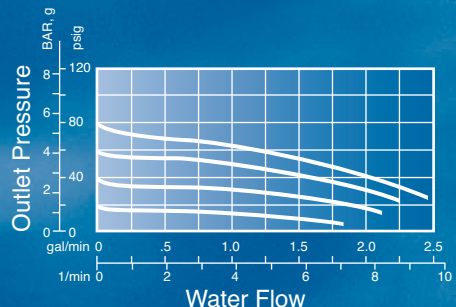

Type 850/860/870 Specifications

| Type/Media | 850: Compressed Air | 860: Compressed Air or Water | 870: Food Grade Potable Water Regulator |
|--------------------------------|--|--|---|
| Flow Capacity | 24 scfm (48 m3/hr) at 100 psig (6.9 BAR) supply, 60 psig (4.1 BAR) output | 2.2 gal/min. | |
| Relief Capacity | 0.5 scfm (.85 m3/hr) Downstream pressure 10 psig (0.7 BAR) above setpoint | N/A | |
| Maximum Supply Pressure | 250 psig (17.2 BAR) | 150 psig (10.0 BAR) | |
| Air Consumption | Less than 6 scfh (0.17 m3/hr) | N/A | |
| Operating Temperature | 0°F to 150°F (-18°C to 60°C) | | |
| Porting | Inlet and outlet- 1/8" or 1/4" NPT/BSP Gauge (2) - 1/8" NPT/BSP | | |
| Output Ranges | 0-5 psig (0-0.4 BAR) 0-15 psig (0-1.0 BAR) 0-30 psig (0-2.1 BAR) | 0-60 psig (0-4.1 BAR) 0-100 psig (0-6.9 BAR) | |
| Materials | Body: Epoxy Coated Zinc Bonnet, Valve Seat: Acetal Diaphragm, O-ring: Nitrile/Nylon Valve Plug: Brass/Nitrile | Electroless Nickel Plated Zinc Acetal Nitrile/Nylon Brass/Nitrile | NSF Electrodeposited Chromium Plated Zinc FDA Acetal Food Grade Nitrile/Nylon Lead-free Brass and Food Grade Nitrile |
| Weight | 4.0 oz. (113 g) | | |

Dimensional Drawings

Optional Mounting Bracket

P/N 446-707-034

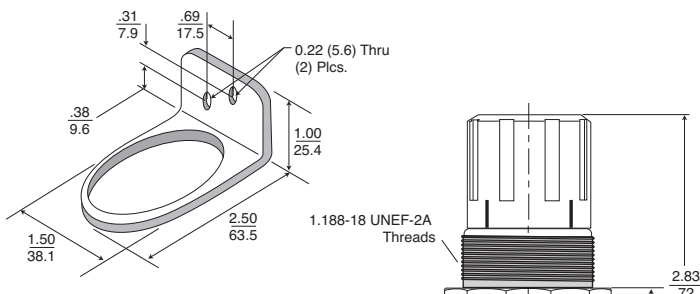

Optional Panel Nut

P/N 442-734-040

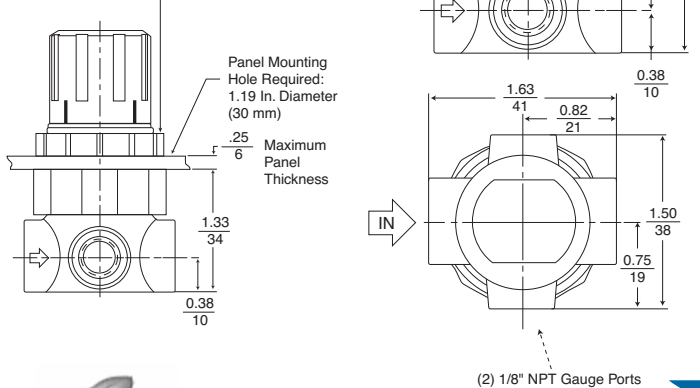

Ordering Information

Use this coding system to order

Model

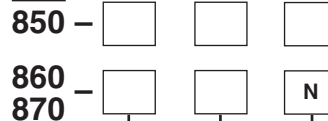

Port Size

- A 1/8" NPT
- B 1/4" NPT
- C 1/8" BSP
- D 1/4" BSP

Output psig BAR

| Output | psig | BAR |
|--------|-------|-------|
| E | 0-5 | 0-0.4 |
| A | 0-15 | 0-1.0 |
| B | 0-30 | 0-2.1 |
| C | 0-60 | 0-4.1 |
| D | 0-100 | 0-6.9 |

Options

N Non-Relieving

For constant flow or downstream pressure relief applications
Note: Standard feature on Type 860 and 870 units

Accessories

Mounting Bracket: P/N 446-707-034 Panel Nut: P/N 442-734-040
Gauge: 0-15 psi P/N 446-725-005 Gauge: 0-30 psi P/N 446-725-006
Gauge: 0-60 psi P/N 446-725-007 Gauge: 0-160 psi P/N 446-725-008

Warranty

ControlAir, Inc. products are warranted to be free from defects in materials and workmanship for a period of eighteen months from the date of sale, provided said products are used according to ControlAir, Inc. recommended usages. ControlAir, Inc.'s liability is limited to the repair, purchase price refund, or replacement in kind, at ControlAir, Inc.'s sole option, of any products proved defective. ControlAir, Inc. reserves the right to discontinue manufacture of any products or change products materials, designs or specifications without notice. Note: ControlAir does not assume responsibility for the selection, use, or maintenance of any product. Responsibility for the proper selection, use, and maintenance of any ControlAir product remains solely with the purchaser and end user.

