

## Multivariable Vortex Mass Flow Meter

### Features

- Mass flow monitoring of most gases and liquids
- Smart electronics extends range down to a Reynolds number of 5000
- Ideal for steam applications
- Selectable outputs for five process parameters in one integrated meter:
  - mass flow rate
  - volumetric flow rate
  - temperature
  - pressure
  - density
- Field-configurable ranges, alarms, outputs and displays
- Field configurable via six push buttons activated with a magnet through explosion-proof window
- Rangeability up to 30:1
- Temperature up to 750° F
- Pressure up to 1500 psig
- In-line and insertion configurations
- FM approval
- CSA and ATEX approvals pending
- Flow computer integrates AGA-8 equations for natural gas
- Full implementation of HART protocol

**SIERRA**  
INSTRUMENTS, INC.  
THE MASS FLOW COMPANY

5 Harris Court, Bldg. L  
Monterey CA 93940  
831/373-0200  
800/866-0200  
FAX: 831/373-4402  
[www.sierrainstruments.com](http://www.sierrainstruments.com)

ISO  
REGISTERED  
9001

# 240 Series Innova-Mass<sup>®</sup>



### Description

**S**ierra Instruments' Innova-Mass<sup>®</sup> Multivariable Vortex Mass Flow Meter provides a reading of five process parameters from a single entry point in the pipeline. The meter measures the fluid's velocity, temperature, and pressure and calculates mass flow rate, volumetric flow rate and density. Sensing all process parameters at a single location in one integrated meter greatly improves measurement accuracy and reduces total installed cost.

The Series 240 in-line meters are available in 0.5, 0.75, 1, 1.5, 2, 3, 4, 6 and 8-inch sizes with ANSI flange or wafer flow bodies. The Series 241 insertion meters can be used on pipe sizes from two inches and greater. They are available with flanged or Male NPT process connections. Optional "hot-tap" hardware including packing gland probe seal, retractor, and isolation valves are also available.

For information online...

[www.sierrainstruments.com](http://www.sierrainstruments.com)

The information contained herein is subject to change without notice.

### In-Line Dimensional Specifications

#### 240 Flanged In-line—Side View

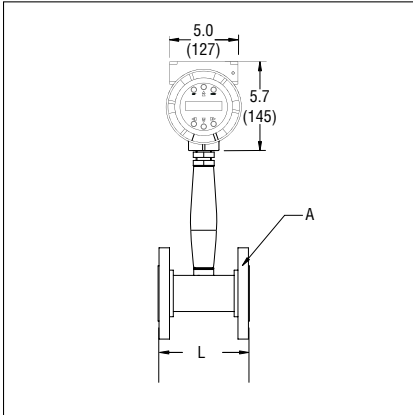

#### 240 Flanged In-line—Outlet View

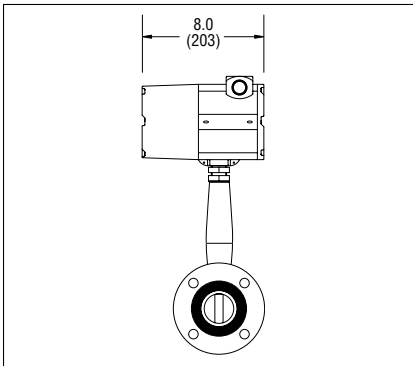

#### 240 Wafer—Side View

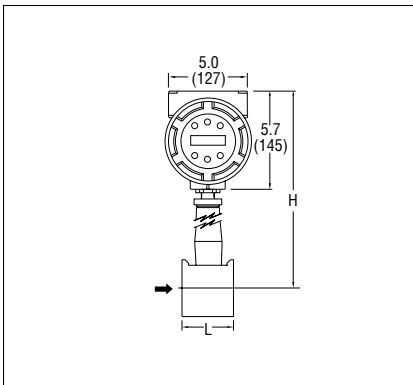

#### 240 Wafer—Outlet View

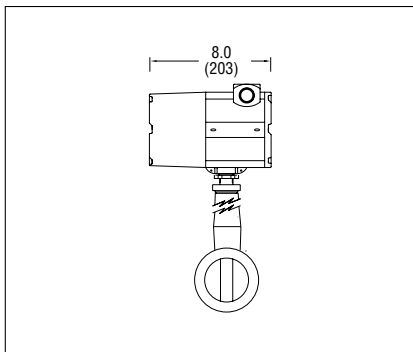

### In-Line Table

240 INNOVA-FLO® SIZES			
Flow Body Size	A	L	H
0.5-inch SCH. 80	150 lb Flange	4.56 (116)	14.8 (376)
	300 lb Flange	4.56 (116)	14.8 (376)
	600 lb Flange	4.56 (116)	14.8 (376)
	1.4 Wafer O.D.	4.56 (116)	14.8 (376)
0.75-inch SCH. 80	150 lb Flange	4.8 (122)	15.0 (381)
	300 lb Flange	4.8 (122)	15.0 (381)
	600 lb Flange	4.8 (122)	15.0 (381)
	1.7 Wafer O.D.	4.8 (122)	15.0 (381)
1-inch SCH. 80	150 lb Flange	4.94 (126)	15.0 (381)
	300 lb Flange	4.94 (126)	15.0 (381)
	600 lb Flange	4.94 (126)	15.0 (381)
	2.0 Wafer O.D.	2.8 (71)	14.8 (376)
1.5-inch SCH. 80	150 lb Flange	5.5 (140)	15.1 (384)
	300 lb Flange	5.5 (140)	15.1 (384)
	600 lb Flange	5.5 (140)	15.1 (384)
	2.9 Wafer O.D.	2.8 (71)	15.1 (384)
2-inch SCH. 80	150 lb Flange	6.0 (153)	15.3 (389)
	300 lb Flange	6.0 (153)	15.3 (389)
	600 lb Flange	6.0 (153)	15.3 (389)
	3.7 Wafer O.D.	3.0 (76)	15.3 (389)
3-inch SCH. 80	150 lb Flange	6.9 (175)	15.8 (401)
	300 lb Flange	6.9 (175)	15.8 (401)
	600 lb Flange	6.9 (175)	15.8 (401)
	5.0 Wafer O.D.	4.0 (102)	15.8 (400)
4-inch SCH. 80	150 lb Flange	8.0 (203)	16.2 (411)
	300 lb Flange	8.0 (203)	16.2 (411)
	600 lb Flange	8.0 (203)	16.2 (411)
	6.2 Wafer O.D.	4.7 (119)	16.2 (412)
6-inch SCH. 80	150 lb Flange	9.0 (229)	17.3 (439)
	300 lb Flange	9.0 (229)	17.3 (439)
	600 lb Flange	9.0 (229)	17.3 (439)
	9.0 Wafer O.D.	2.9 (74)	17.3 (439)
8-inch SCH. 80	150 lb Flange	10.5 (267)	18.2 (462)
	300 lb Flange	10.5 (267)	18.2 (462)
	600 lb Flange	10.5 (267)	18.2 (462)
	12.0 Wafer O.D.	2.9 (74)	18.2 (462)

### Insertion Dimensional Specifications

#### Gate Valve

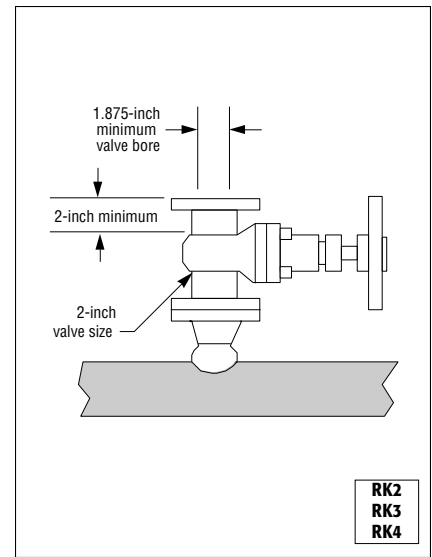

### Insertion Table

Model Code / Probe Seal / Process Connection
CM / Compression / Two-inch Male NPT
CF / Compression / 150 lb flange
CG / Compression / 300 lb flange
CH / Compression / 600 lb flange
PM / Packing Gland / Two-inch Male NPT <sup>1</sup>
PMR / Packing Gland / Two-inch Male NPT with Retractor <sup>2</sup>
PF / Packing Gland / 150 lb flange <sup>1</sup>
PFR / Packing Gland / 150 lb flange with Retractor <sup>2</sup>
PG / Packing Gland / 300 lb flange <sup>1</sup>
PGR / Packing Gland / 300 lb flange with Retractor <sup>2</sup>
PHR / Packing Gland / 600 lb flange with Retractor <sup>2</sup>

Notes: (1) Can be used with removable retractor.  
 (2) Retractor is permanently mounted to meter.

### 241 Compression, Flange

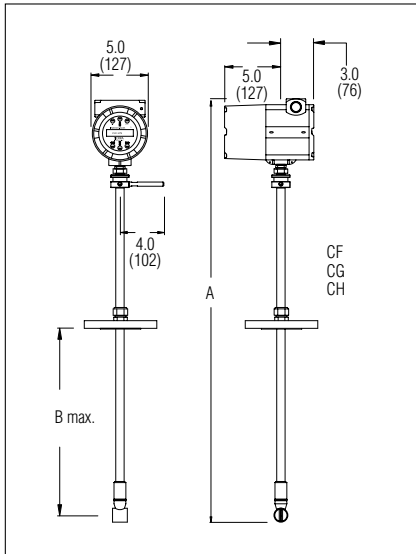

### 241 Compression, Male NPT

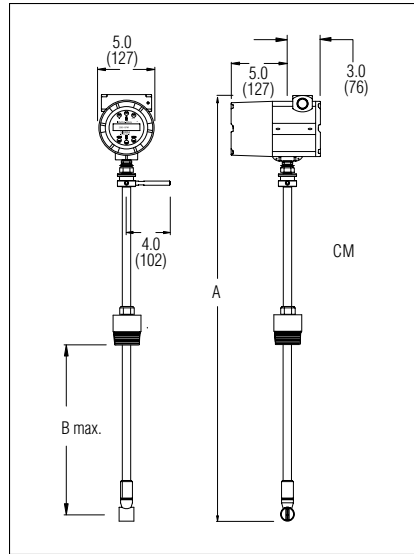

### 241 Packing Gland, Flange

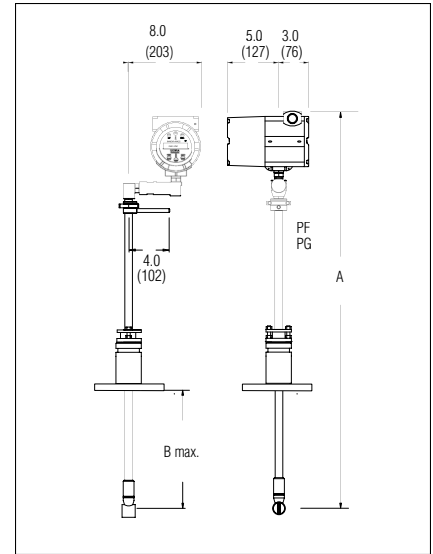

### 241 Packing Gland, Male NPT, Retractor

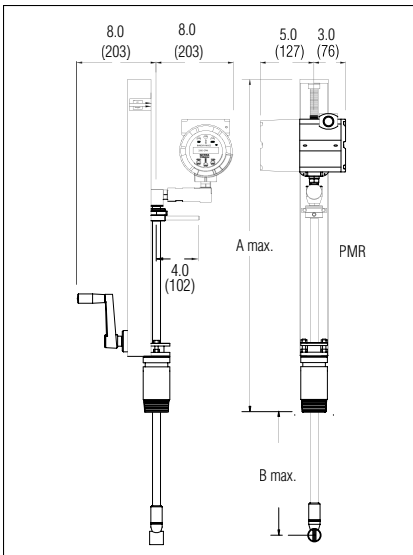

### 241 Packing Gland, Male NPT

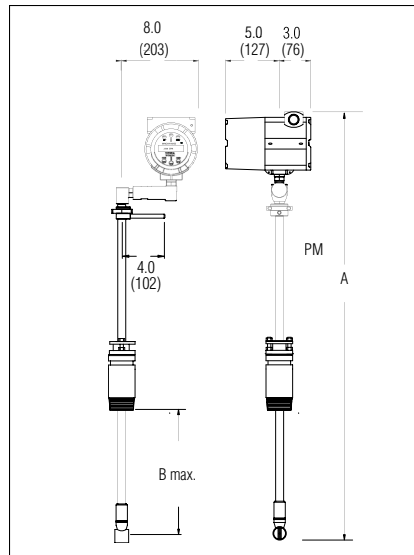

### 241 Packing Gland, Flange, Retractor

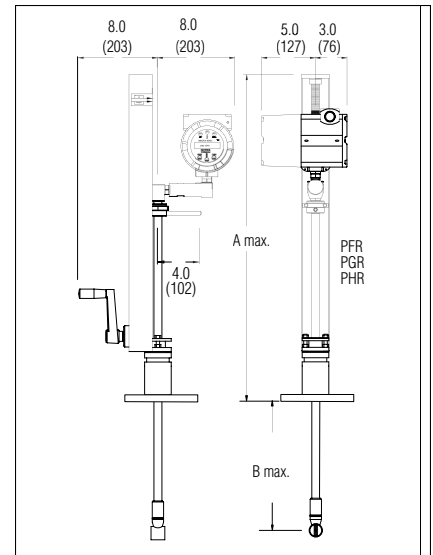

#### 241 INNOVA-MASS® SIZES

Standard Probe		Compact Probe		Extended Probe	
A	B	A	B	A	B
41.0 (1041.0)	26.2 (665.0)	24.6 (625.0)	9.8 (249.0)	53.0 (1340.0)	38.2 (920.0)
41.0 (1041.0)	27.3 (639.0)	24.6 (625.0)	10.9 (277.0)	53.0 (1340.0)	39.3 (998.0)
41.0 (1041.0)	27.2 (691.0)	24.6 (625.0)	10.8 (274.0)	53.0 (1340.0)	39.2 (996.0)
41.0 (1041.0)	26.8 (681.0)	24.6 (625.0)	10.4 (264.0)	53.0 (1340.0)	38.8 (986.0)
40.5 (1029.0)	21.5 (546.0)	N/A	N/A	52.5 (1334.0)	33.5 (850.9)
40.5 (1029.0)	21.5 (546.0)	N/A	N/A	52.5 (1334.0)	33.5 (850.9)
40.5 (1029.0)	21.1 (536.0)	N/A	N/A	52.5 (1334.0)	33.1 (841.0)
40.5 (1029.0)	21.1 (536.0)	N/A	N/A	52.5 (1334.0)	33.1 (841.0)
40.5 (1029.0)	21.1 (536.0)	N/A	N/A	52.5 (1334.0)	33.1 (841.0)
40.5 (1029.0)	21.1 (536.0)	N/A	N/A	52.5 (1334.0)	33.1 (841.0)
40.5 (1029.0)	21.1 (536.0)	N/A	N/A	52.5 (1334.0)	33.1 (841.0)

## Dimensional Specifications

### 240/241 Remote—Front View

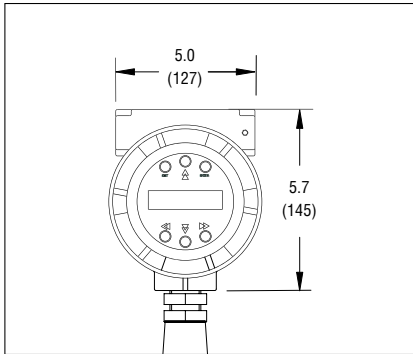

### 240/241 Remote—Side View

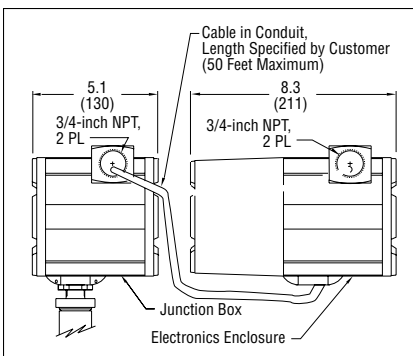

### Remote Rear Bracket Mounted Electronics

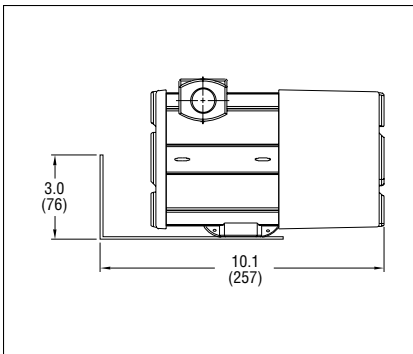

### Mounting Holes for Remote Rear Bracket

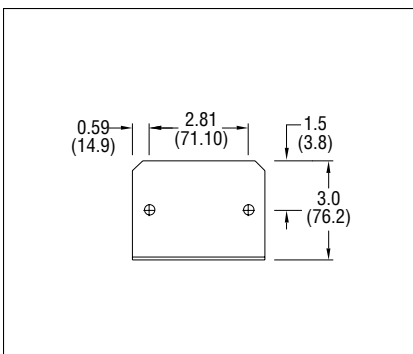

### STRAIGHT PIPE LENGTH REQUIREMENTS (In Number of Internal Diameters, D)

	Upstream	Downstream
One 90° elbow before meter	10 D	5 D
Two 90° elbows before meter	15 D	5 D
Two 90° elbows before meter out of plane (If three 90° bends present, double recommend length)	25 D	10 D
Reduction before meter	10 D	5 D
Expansion before meter	20 D	5 D
Regulator or valve partially closed before meter (If valve wide open, base length requirements on fitting directly preceding it)	25 D	10 D

### Weight

#### 240 IN-LINE METER

Connection Size	ANSI 150 lb		ANSI 300 lb		ANSI 600 lb	
	lb	kg	lb	kg	lb	kg
0.5-inch flange	12.0	5.5	12.5	5.7	13	5.9
0.75-inch flange	13.0	5.9	14.0	6.4	14.5	6.6
1-inch flange	13.5	6.1	16.4	7.4	16.4	7.4
1.5-inch flange	14.6	6.6	22.7	10.3	24.8	11.2
2-inch flange	19.5	8.8	26.9	12.2	33.2	15.1
3-inch flange	27.5	12.5	39.5	17.9	56.3	25.5
4-inch flange	43.5	19.7	60.5	27.4	96.2	43.6
6-inch flange	48.4	22.0	96.2	43.6	178	80.8
8-inch flange	71.0	32.2	149	67.4	300	136
1-inch wafer	—	—	—	—	10.1	4.6
1.5-inch wafer	—	—	—	—	11.8	5.4
2-inch wafer	—	—	—	—	14.2	6.4
3-inch wafer	—	—	—	—	22.7	10.3
4-inch wafer	—	—	—	—	33.0	15.0

#### 241 INSERTION METER

Connection Size	lb	kg
Compression Fitting, Male NPT	13.8	6.2
Compression Fitting, 150 lb Flange	16.3	7.3
Compression Fitting, 300 lb Flange	18.3	8.3
Compression Fitting, 600 lb Flange	19.3	8.7
Packing Gland, Male NPT	15.8	7.1
Packing Gland, Male NPT with Retractor	25.3	11.5
Packing Gland, 150 lb Flange	20.8	9.4
Packing Gland, 150 lb Flange with Retractor	30.3	13.7
Packing Gland, 300 lb Flange	24.8	11.3
Packing Gland, 300 lb Flange with Retractor	34.3	15.5
Packing Gland, 600 lb Flange with Retractor	35.3	16.0

## Performance Specifications

### Accuracy

Process Variables	240 Series In-Line Meters		241 Series Insertion Meters <sup>(1)</sup>	
	Liquids	Gas and Steam	Liquids	Gas and Steam
Mass Flow Rate	± 1% of rate over a 30:1 range <sup>(3)</sup>	± 1.5% of rate <sup>(2)</sup> over a 30:1 range <sup>(3)</sup>	± 1.5% of rate over a 30:1 range <sup>(3)</sup>	± 2% of rate <sup>(2)</sup> over a 30:1 range <sup>(3)</sup>
Volumetric Flow Rate	± 0.7% of rate over a 30:1 range <sup>(3)</sup>	± 1% of rate over a 30:1 range <sup>(3)</sup>	± 1.2% of rate over a 30:1 range <sup>(3)</sup>	± 1.5% of rate over a 30:1 range <sup>(3)</sup>
Temperature	± 2° F (± 1° C)	± 2° F (± 1° C)	± 2° F (± 1° C)	± 2° F (± 1° C)
Pressure	0.4% of transducer full scale	0.4% of transducer full scale	0.4% of transducer full scale	0.4% of transducer full scale
Density	0.3% of reading	0.5% of reading <sup>(2)</sup>	0.3% of reading	0.5% of reading <sup>(2)</sup>

Notes: (1) Accuracies stated are for the total mass flow through the pipe.

(2) Over 50 to 100% of the pressure transducer's full scale.

(3) Nominal rangeability is stated. Precise rangeability depends on fluid and pipe size.

### Repeatability

Mass Flow Rate . . . . .	0.2% of rate
Volumetric Flow Rate . . .	0.1% of rate
Temperature . . . . .	± 0.2° F (± 0.1° C)
Pressure . . . . .	0.05% of full scale
Density . . . . .	0.1% of reading

### Stability Over 12 Months

Mass Flow Rate . . . . .	0.2% of rate maximum
Volumetric Flow Rate . . .	Negligible error
Temperature . . . . .	± 0.1° F (± 0.5° C) maximum
Pressure . . . . .	0.1% of full scale maximum
Density . . . . .	0.1% of reading maximum

### Response Time

Adjustable from 1 to 100 seconds

## Operating Specifications

### Material Compatibility

240 . . . . .	Any gas, liquid or steam compatible with 316L stainless steel, C276 hastelloy or A105 carbon steel. Not recommended for multi-phase fluids.
241 . . . . .	Any gas, liquid or steam compatible with 316L stainless steel. Not recommended for multi-phase fluids.

### Flow Rates

Typical mass flow ranges are given in the following table. Precise flow ranges depend on the fluid and pipe size. 241 insertion meters are applicable to pipe sizes from 2 inch and greater. Consult factory for sizing program.

WATER MINIMUM AND MAXIMUM FLOW RATES									
	0.5-In.	0.75-In.	1-Inch	1.5-Inch	2-Inch	3-Inch	4-Inch	6-Inch	8-Inch
gpm	0.9	3	2.2	5.5	9.2	21	36	81	142
	22	40	67	166	276	618	1076	2437	4270
m <sup>3</sup> /hr	0.2	0.7	0.5	1.3	2.1	4.7	8.1	18	32
	5	9	15	38	63	140	244	554	970

AIR MINIMUM AND MAXIMUM FLOW RATES (scfm) <sup>(1)</sup>									
Pressure	0.5-In.	0.75-In.	1-Inch	1.5-Inch	2-Inch	3-Inch	4-Inch	6-Inch	8-Inch
0 psig	1.8	3	5	13	22	50	88	198	347
	17	40	90	221	369	826	1438	3258	5708
100 psig	4.9	9	15	37	62	138	240	543	952
	135	318	701	1728	2879	6447	11222	25421	44536
200 psig	7	12	20	50	83	185	322	730	1279
	255	608	1313	4740	5389	12067	21006	47585	67122
300 psig	8.5	15	24	59	98	220	382	866	1518
	375	893	1924	4750	7900	17687	30789	48821	64552
400 psig	10	17	27	66	110	247	430	975	1708
	500	1178	2535	6246	10410	23308	31141	46884	61990
500 psig	11	21	29	72	120	270	469	1063	1862
	620	1464	3147	7752	12920	22592	29834	44915	59387

Note: (1) Standard conditions are 70° F and 1 atmosphere.

SATURATED STEAM MINIMUM AND MAXIMUM FLOW RATES (lb/hr)									
Pressure	0.5-In.	0.75-In.	1-Inch	1.5-Inch	2-Inch	3-Inch	4-Inch	6-Inch	8-Inch
5 psig	5.7	12	20	49	82	183	319	722	1265
	52	122	265	652	1087	2434	4237	9598	16815
100 psig	7.1	28	46	112	187	419	729	1651	2893
	270	639	1385	3413	5688	12735	22168	50219	87980
200 psig	13	37	61	151	252	565	984	2229	3905
	495	1164	2524	6217	10362	23200	40385	91485	160275
300 psig	19	45	74	182	304	681	1185	2685	4704
	718	1690	3662	9021	15035	33664	58601	132750	232570
400 psig	25	52	85	209	349	781	1359	3078	5393
	944	2220	4814	11859	19764	44253	77033	174505	305721
500 psig	30	58	95	233	389	870	1515	3433	6014
	1176	2640	5986	14745	24575	55025	95784	216983	331080

### Differential Pressure Requirements, $\Delta P$

Permanent pressure loss of in-line meters for air at 68°F (20°C) and 14.70 psi (1.104 bara).

Permanent pressure loss of in-line meters for water at 68°F (20°C).

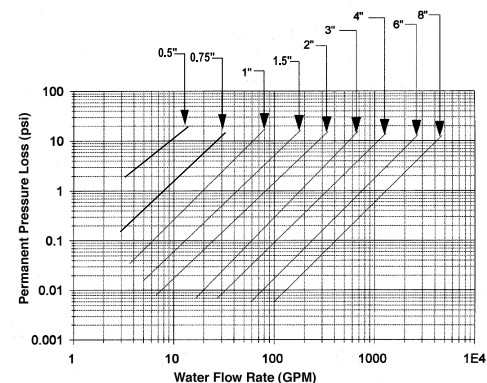
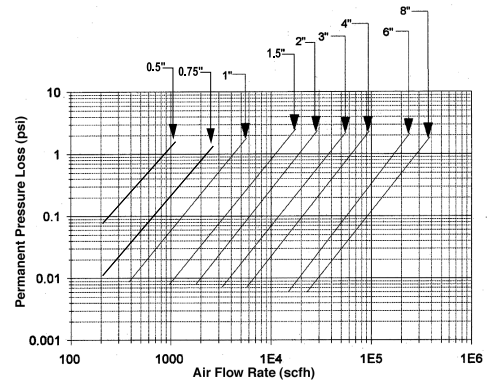

### Linear Range

Smart electronics corrects for lower flow down to a Reynolds number of 5,000. The Reynolds number is calculated using the fluid's actual temperature and pressure monitored by the meter. Rangeability depends on the fluid, process connections and pipe size. Consult factory for your application.

Velocity rangeability under ideal conditions is as follows:

- Liquids 30:1 . . . . . 1 foot per second velocity minimum  
30 feet per second velocity maximum
- Gases 30:1 . . . . . 10 feet per second velocity minimum  
300 feet per second velocity maximum

### Process Fluid Pressure

240 PRESSURE RATINGS		
PROCESS CONNECTION	MATERIAL	RATING
Flanged	316L SS, A105 Carbon Steel, C276 Hastelloy	150, 300, 600 lb
Wafer	316L SS, A105 Carbon Steel, C276 Hastelloy	600 lb

241 PRESSURE RATINGS				
Probe Seal	Process Connection	Material	Rating	Ordering Code
Compression Fitting	2-inch Male NPT	316 L SS	ANSI 600 lb	CM
	2-inch 150 lb flange	316 L SS	ANSI 150 lb	CF
	2-inch 300 lb flange	316 L SS	ANSI 300 lb	CG
	2-inch 600 lb flange	316 L SS	ANSI 600 lb	CH
Packing Gland	2-inch Male NPT	316 L SS	50 psig	PM
	2-inch 150 lb flange	316 L SS	50 psig	PF
	2-inch 300 lb flange	316 L SS	50 psig	PG
Packing Gland with Removable Retractor	2-inch Male NPT	316 L SS	ANSI 300 lb	PM, RR
	2-inch 150 lb flange	316 L SS	ANSI 150 lb	PF, RR
	2-inch 300 lb flange	316 L SS	ANSI 300 lb	PG, RR
Packing Gland with Permanent Retractor	2-inch Male NPT	316 L SS	ANSI 600 lb	PMR
	2-inch 150 lb flange	316 L SS	ANSI 150 lb	PFR
	2-inch 300 lb flange	316 L SS	ANSI 300 lb	PGR
	2-inch 600 lb flange	316 L SS	ANSI 600 lb	PHR

### Pressure Transducer Ranges

PRESSURE SENSOR RANGES <sup>(1)</sup> , psia(bar)			
Full Scale Operating Pressure		Maximum Over-Range Pressure	
psia	(bara)	psia	(bara)
30	2	60	4
100	7	200	14
300	20	600	41
500	34	1000	69
1500	100	1500	100

Note: (1) To maximize accuracy, specify the lowest full scale operating pressure range for the application. To avoid damage, the flow meter must never be subjected to pressure above the over-range pressure shown above.

### Power Requirements

18 to 36 VDC, 100 mA (add 20mA per output, up to 60mA)  
100 to 240 VAC, 50/60 Hz, 25 watts

### Display

Alphanumeric 2 x 16 LCD digital display  
Six pushbuttons switches (up, down, right, left, enter, exit) operable through the display glass of the explosion-proof enclosure  
Viewing at 90° mounting intervals

Teflon is a registered trademark of DuPont.

### Process Fluid & Ambient Temperature

- Process Fluid . . . . . Standard Temperature Sensor:  
-40° to 400°F (-40° to 205°C)  
Medium Temperature Sensor:  
-40° to 500°F (-40° to 260°C)  
High Temperature Sensor:  
250° to 750°F (120° to 400°C)
- Ambient . . . . . Operating: -5° to 140°F (-20° to 60°C)  
Storage: -40° to 150°F (-40° to 65°C)  
0-98% relative humidity, non-condensing conditions

### Output Signals<sup>(1)</sup>

- Analog . . . . . Three field rangeable, simultaneous linear 4-20 mA output signals (1000 ohms maximum loop resistance) selected by user from the five parameters—mass flow rate, volumetric flow rate, temperature, pressure and density
- Pulse . . . . . Pulse output for totalization is a 50-millisecond duration pulse operating a solid-state relay capable of switching 40 VDC, 40 mA maximum

Note: (1) All outputs are optically isolated and require external power for operation

### Alarms

Up to three programmable solid-state relays for high, low or window alarms capable of switching 40 VDC, 40 mA maximum

### Totalizer

Based on user-determined flow units, nine full digits, with rollover at 4, 294, 967, 295. Total stored in non-volatile memory

## Physical Specifications

### Wetted Materials

- 240 . . . . . 316L stainless steel standard  
C276 hastelloy or A105 carbon steel optional  
Teflon-based thread sealant on pressure transducer
- 241 . . . . . 316L stainless steel  
Teflon® packing gland below 500°F (260°C)  
Graphite packing gland above 500°F (260°C)  
Teflon-based thread sealant on pressure transducer

### Enclosure

NEMA 4X cast enclosure

### Electrical Ports

Two 3/4-inch female NPT ports

### Mounting Connections

- 240 . . . . . Wafer or 150, 300, 600 lb ANSI flange
- 241 . . . . . Permanent Installation:  
Two inch Male NPT; 150, 300, 600 lb ANSI flange with compression fitting probe seal  
Hot Tap<sup>(1)</sup> Installation:  
Two inch Male NPT; 150, 300, 600 lb ANSI flange; and optional retractor with packing gland probe seal

Note: (1) Removable under line pressure.

### Mounting Position

- 240 . . . . . No effect
- 241 . . . . . Meter must be perpendicular within ± 5° of the pipe centerline

### FM Approvals

Explosion proof for Class I, Division 1, Groups B, C & D.  
Dust-ignition proof for Class II/III, Division 1, Groups E, F & G.  
NEMA Type 4x and IP66  
T6 at Tamb=60°C

### Optional Certifications

Construction and Inspection (ANSI/ASME B31.3)  
Materials (NACE MR-01-75(90))

## Ordering the Model 240

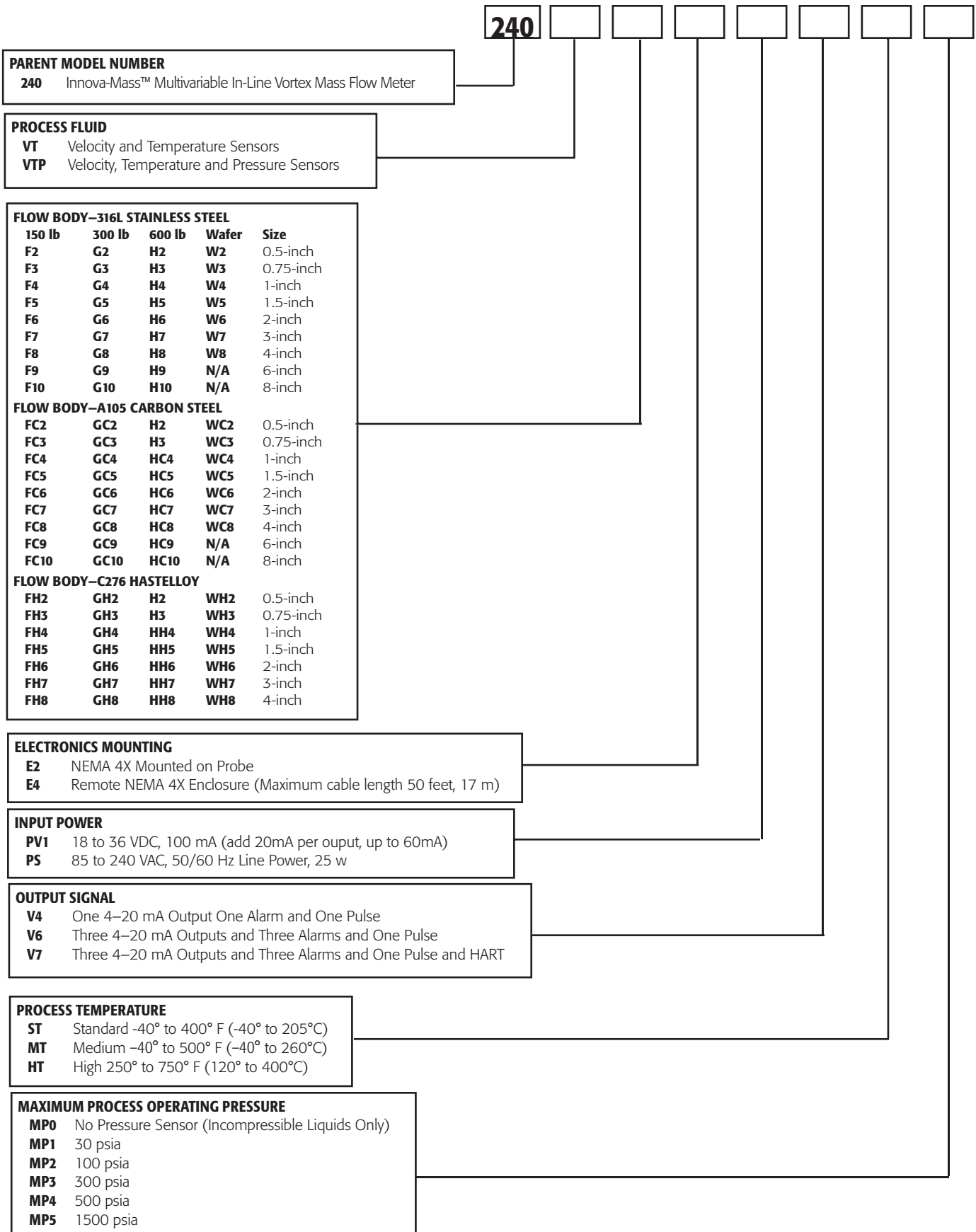

ACCESSORIES (Consult Factory) Material Certificates, Pressure Certificates, Certificate of Conformance, NACE Certification

## Ordering the Model 241

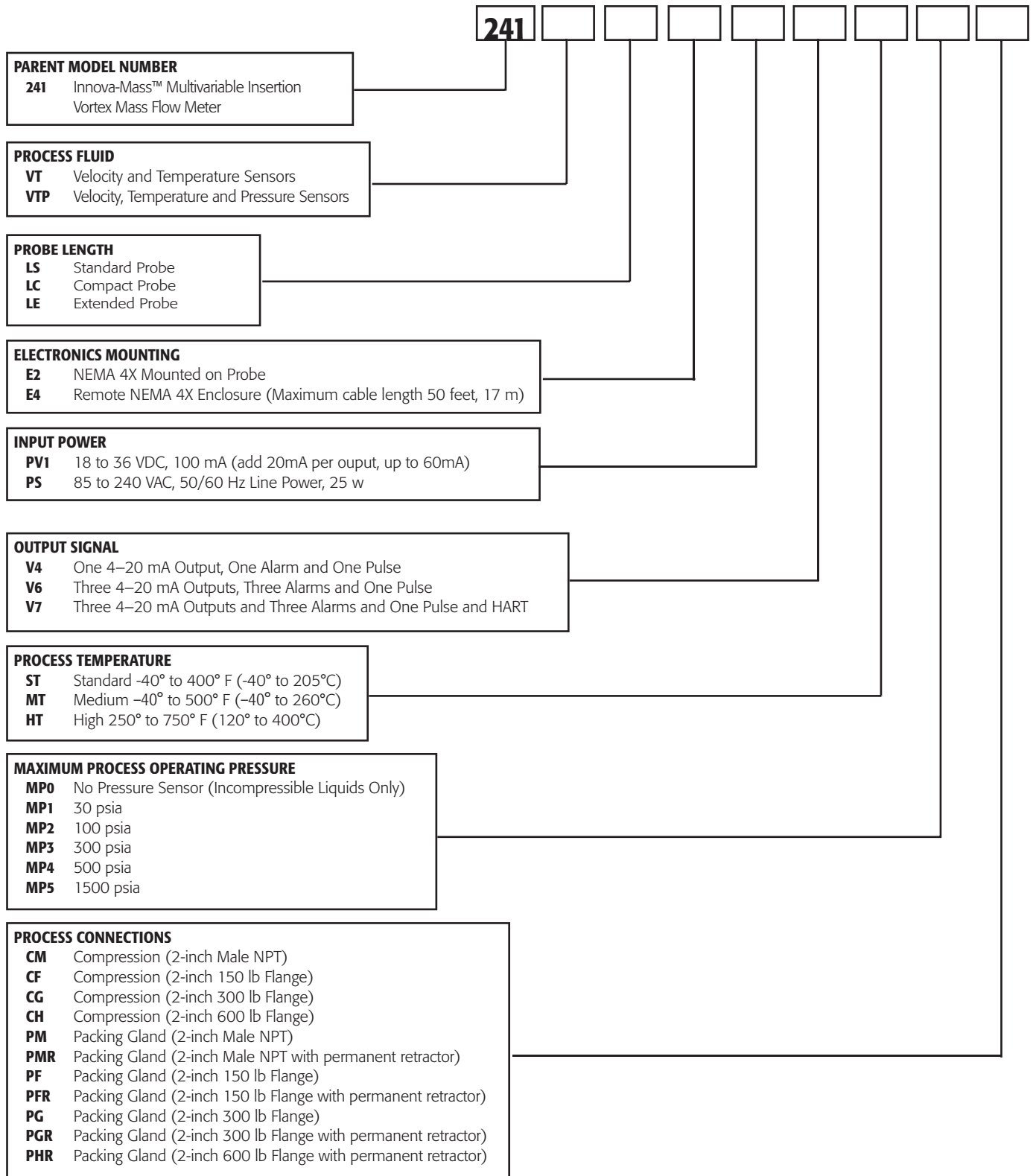

**ACCESSORIES (Consult Factory)** Removable Retractors, Isolated Gate Valves, Mounting Kits, Material Certificates, Pressure Certificates, Certificate of Conformance, NACE Certification